

No.	Name	Note	No.	Name	Note
1	Angle valve	1/4"Flare	12	Angle valve	1/4"Flare
2	Discharge flange	3"	13	Refrigerant service valve	1/4"Flare
3	Solenoid valve	50%(NC)	14	Solenoid valve	Stepless(NC or NO), option
4	Solenoid valve	75%(NC)	15	NOT USED	5/8"Flare, option
5	Solenoid valve	35%(NC)	16	Suction flange	4"
6	Liquid/oil or refrigerant injection connector	3/8"Flare, option	17	Cable box	Standard
7	Capillary		18	Service flange	
8	Check valve	3"	19	Oil drain valve	option
9	Service flange		20	Discharge temp. sensor	110°C
10	Stop Pin		21	Safety Valve	option
11	Oil inlet Connector	5/8"Flare	22	Economizer port	7/8" solder

*All stop valves are optional

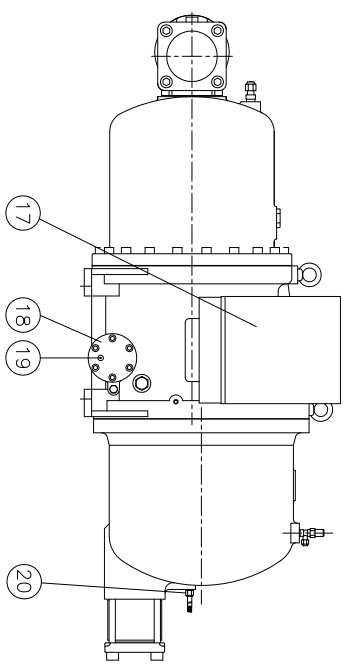
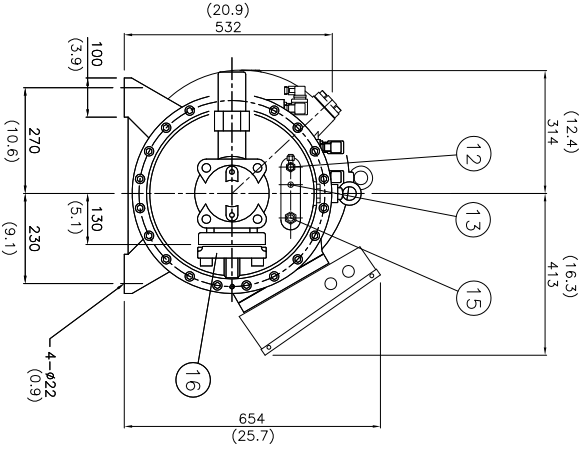
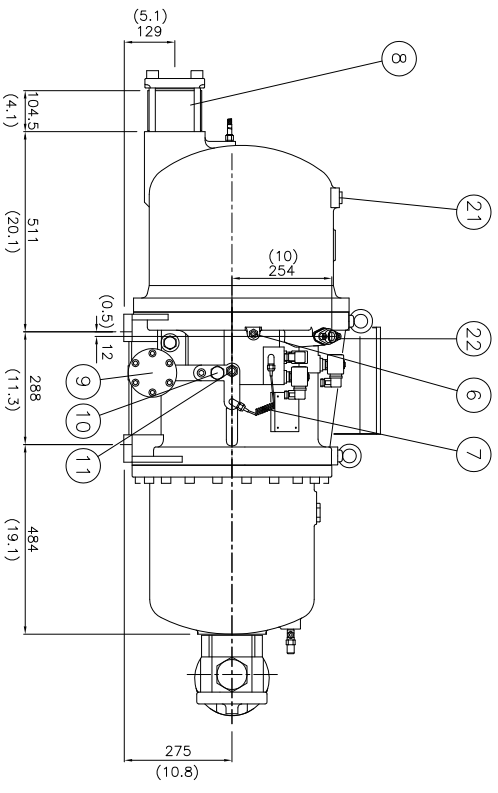
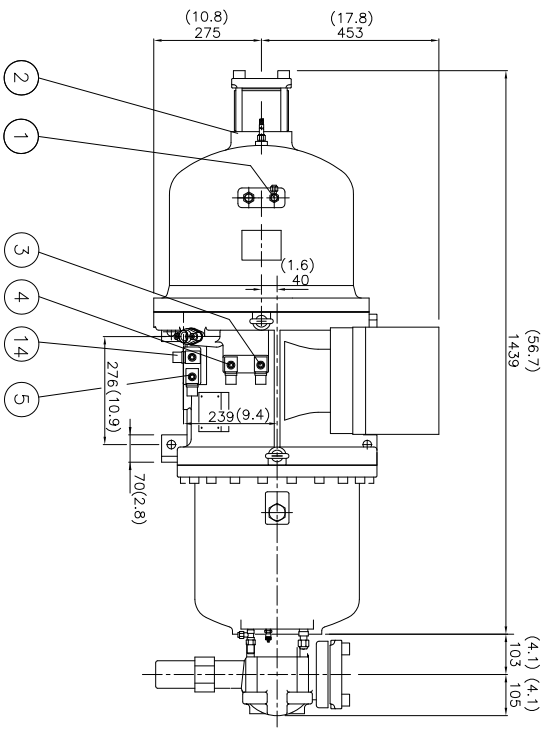

Dimensional Outline Drawing & Component Description
for Stepless or Modulating—Type Capacity Control Application

Hanbell Model	RC2-510BF
Date and Rev.	08/17/2012 A
Drawn By	M. Schreiber



Micro Control Systems, Inc.
5580 Enterprise Parkway
Fort Myers, Florida 33905
Tel. (239) 694-0089 Fax (239) 694-0031
E-mail: compressors@mcscontrols.com

